

RWTM(NSP) - WINDSCREEN WIPER TIMER MODULE FOR NON SELF PARKING WIPER MOTORS*

Thank you for purchasing our Wiper Timer Module, we hope it puts the fun back into driving on a drizzly day!

Your module comes with a three year back to base guarantee from your date of purchase. There is no need to register, we did that when you paid. This does not affect your statutory rights.

In a vehicle with a wiper system which only switches the wipers on or off the RWTM(NSP) will provide wiper sweep intervals of 2, 3, 4, 8 & 12 seconds.

By giving an interval between full sweeps of at least 2 seconds, during which you can switch the Module off, the RWTM(NSP) gives an easy way to park your wipers at the correct position when not in use.

The furthest left position on the Wiper Module's control knob is the "off" position.

Your original wiper switch will still work as before but must be turned off for our Module to provide the intervals.

Our Wiper Module is universal & is suitable for use with most non self park wiper motors.

Please read the following instructions & study the diagrams carefully before installation. Some original early wiper motors provide a very weak wiper drive. In order for the Module to function correctly, please ensure your wiper motor operates sufficiently in all conditions.

Our Timer Module is simple to install, but if you are in any doubt over your ability to install it correctly & safely please consult a qualified technician. Contact us if you have any queries.

A range of connectors is included with your module but the types of connectors you use is entirely your choice.

INSTALLATION INSTRUCTIONS:

NEGATIVE EARTH VEHICLE:

- Disconnect your vehicle's battery before installation.
- Connect the Module's red/black wire to battery positive, using a 2A fuse.
- Connect the Module's blue wire to battery negative.
- Connect the Module's green/purple wire to the wire on one side of the vehicle's original wiper switch & the Module's orange wire to the the wire on the switch's other side.

NOTE: It does not matter which wire goes to which side.

- Mount the RWTM(NSP) rotary control switch to the dashboard in a method of your choice. The switch's shaft can be shortened to suit.
- Reconnect your vehicle's battery.

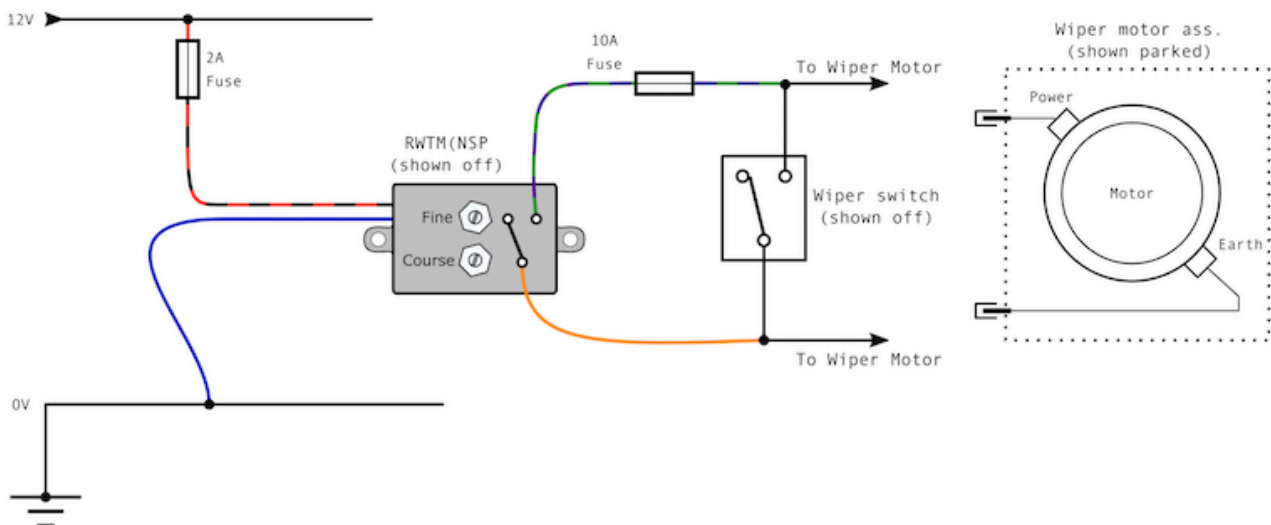

POSITIVE EARTH VEHICLE:

- Disconnect your vehicle's battery before installation.
- Connect the Module's red/black wire to battery negative, using a 2A fuse.
- Connect the Module's blue wire to battery positive.
- Connect the Module's green/purple wire to the wire on one side of the vehicle's original wiper switch & the Module's orange wire to the the wire on the switch's other side.

NOTE: It does not matter which wire goes to which side.

- Mount the RWTM(NSP) rotary control switch to the dashboard in a method of your choice. The switch's shaft can be shortened to suit.
- Reconnect your vehicle's battery.

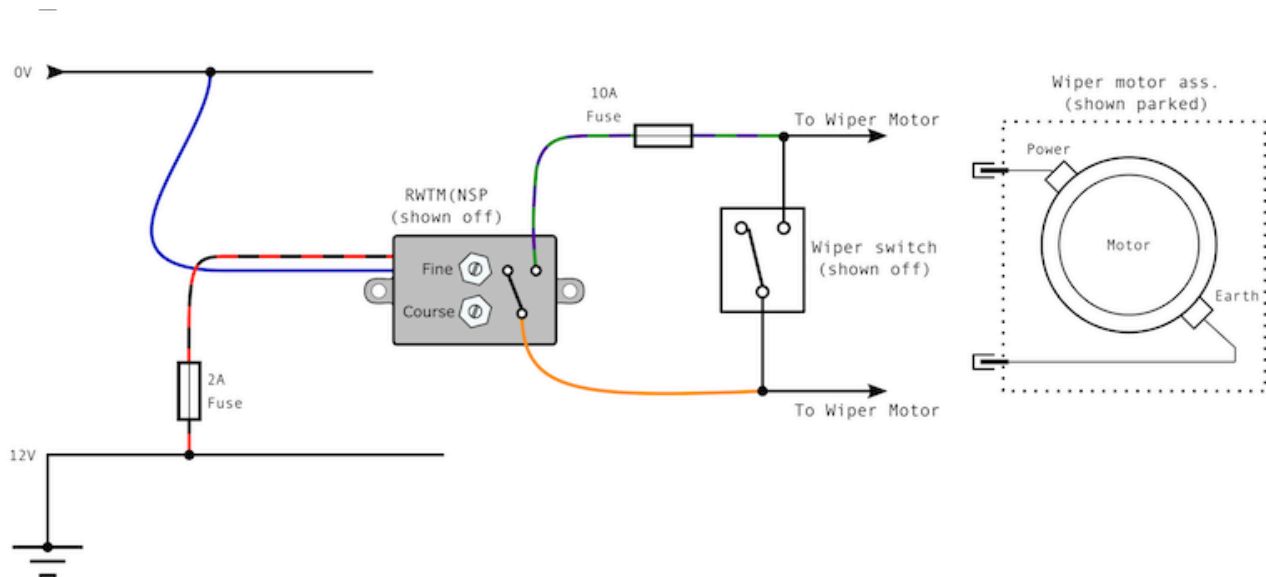

SET UP INSTRUCTIONS:

The interval between the Module's contacts closing is set to give sweep intervals of 2, 3, 4, 8 & 12 seconds.

By setting up the Module to your vehicle, the wipers will stop at the correct park position between each sweep.

This is achieved by using the two trimpot controls on the Module.

The Coarse trimpot is for larger adjustments. When the sweep is nearly correct, use the Fine trimpot to make final, smaller adjustments.

- Ensure your wipers are parked in the correct position.
- Turn the Module's rotary control switch clockwise by 3 clicks (to give a 4 second sweep interval).
- Note where the wipers stop after their sweep. If the wipers operate for too long (they start a second sweep & stop), then turn the Fine or Coarse trimpot anticlockwise.
- If the wipers do not operate for long enough (they stop before completing a full sweep), turn a trimpot clockwise.
- Using the vehicle's original wiper switch, manually put the wipers back to the correct park position after each test.
- Once set up is finished, secure the Module behind the dashboard, or in a position of your choice.

NOTE: If you turn the Module off in the middle of a sweep, they will stop immediately - wait until they have reached the park position & stopped moving.

RETRONICS LTD

The Generator Hub, Kings Wharf, The Quay, Exeter, Devon, EX2 4AN.
Registered in England, registration number: 12280789

This product is not recyclable. Please check with your local authority for suitable end of life disposal.

***DISCLAIMER:** This product is UKCE, UKNI, CE, GPSR & RoHS compliant. The RWTM(NSP) is a generic after market product designed to be compatible with the standard wiring systems & non self parking wiper motors of most classic vehicles. Retronics Ltd can not guarantee compatibility with all vehicles. It is for the purchaser to satisfy themselves as to the suitability of the RWTM(NSP) for their vehicle. Retronics Ltd will not be liable for any loss or damage arising from unsuitable or incorrect installations. If in doubt, always consult a qualified technician.