

RIHM- RETRONICS INDICATOR HAZARD MODULE FOR POSITIVE EARTH VEHICLES

Thank you for purchasing the Retronics Indicator Hazard Module - the ultimate discreet indicator & hazard light installation / upgrade for all classic vehicles & kit cars. Your product comes with a three year back to base guarantee from your date of purchase. There's no need to register, we did that when you paid. This does not affect your statutory rights.

Once installed, the RIHM will operate the vehicle's indicators & hazard lights with consistent & reliable accuracy.

Being fully electronic, the flash rate is not affected by changes in resistance / lamp failure. In the event of a bulb failure, the remaining bulbs will continue to flash at the correct rate. The RIHM is suitable for use with traditional bulbs & LEDs. (LEDs will require suitable resistors).

When your indicator switch is operated, the relevant indicators and the dashboard "Tell Light" will flash.

The RIHM also works if your brake lights also act as rear indicators, without negating the brake light function.

When the hazard light function is engaged (pull knob for "on"), the RIHM will repeatedly supply power to all indicators & the dashboard indicator "Tell Light". The red lamp in the knob will also illuminate.

Please study the following instructions, & accompanying diagram, carefully before installation. The RIHM is simple to install but if you are in any doubt as to your ability to do so, please consult a qualified technician. Feel free to email us with any questions.

NOTES:

*Disconnect the battery before installation.

**If your vehicle has a 6V electrical system, you will need our Voltage Converter (RVCU) as the circuit board in the RIHM requires 12V to operate.

***The RIHM has built in suppression. However (just like using a modern radio, etc.) the extreme amount of RFI caused by using unsuppressed HT leads may cause issues - the indicators may flash rapidly whilst the engine is running. In this case, additional suppression will be required.

INSTALLATION INSTRUCTIONS:

The Installation Diagram can be found on Page 2.

- 1/ Connect the Module's terminal 1 to battery 0V via a 15A fuse.
- 2/ Connect terminal 6 to +12V (ie: chassis), via a 2A fuse.
- 3/ Connect terminals 7 & 8 to right front & rear indicators respectively.
- 4/ Connect terminals 2 & 3 to left front & rear indicators respectively.
- 5/ Connect terminal 4 to your indicator switch left turn feed & terminal 9 to the switch's right turn feed.
- 6/ Terminal 5 can be connected to the vehicle dashboard Tell Light.
*Alternatively, if your vehicle has separate left & right Tell Lights, you can connect these to Terminals 2 & 7 respectively.
- 7/ Terminal 10 connects the hazard light pull switch to battery 0V.
- 8/ Mount the control knob to the dashboard, in a position & manner of your choice.
If the mounting point is isolated from the chassis - for example is wood - connect the switch's side contact to +12V (chassis) for the switch's lamp to work.
*You may opt to use an alternative hazard light switch of your choice.
- 9/ Locate the RIHM behind the dashboard, or similarly convenient location.
- 10/ If your brake lights are also the rear indicators, the additional terminal must be connected to the brake light switch, as shown in the diagram.

Best regards,

Andy & Matt

Retronics Ltd.

**RIHM FOR POSITIVE EARTH VEHICLES
INSTALLATION DIAGRAM:**

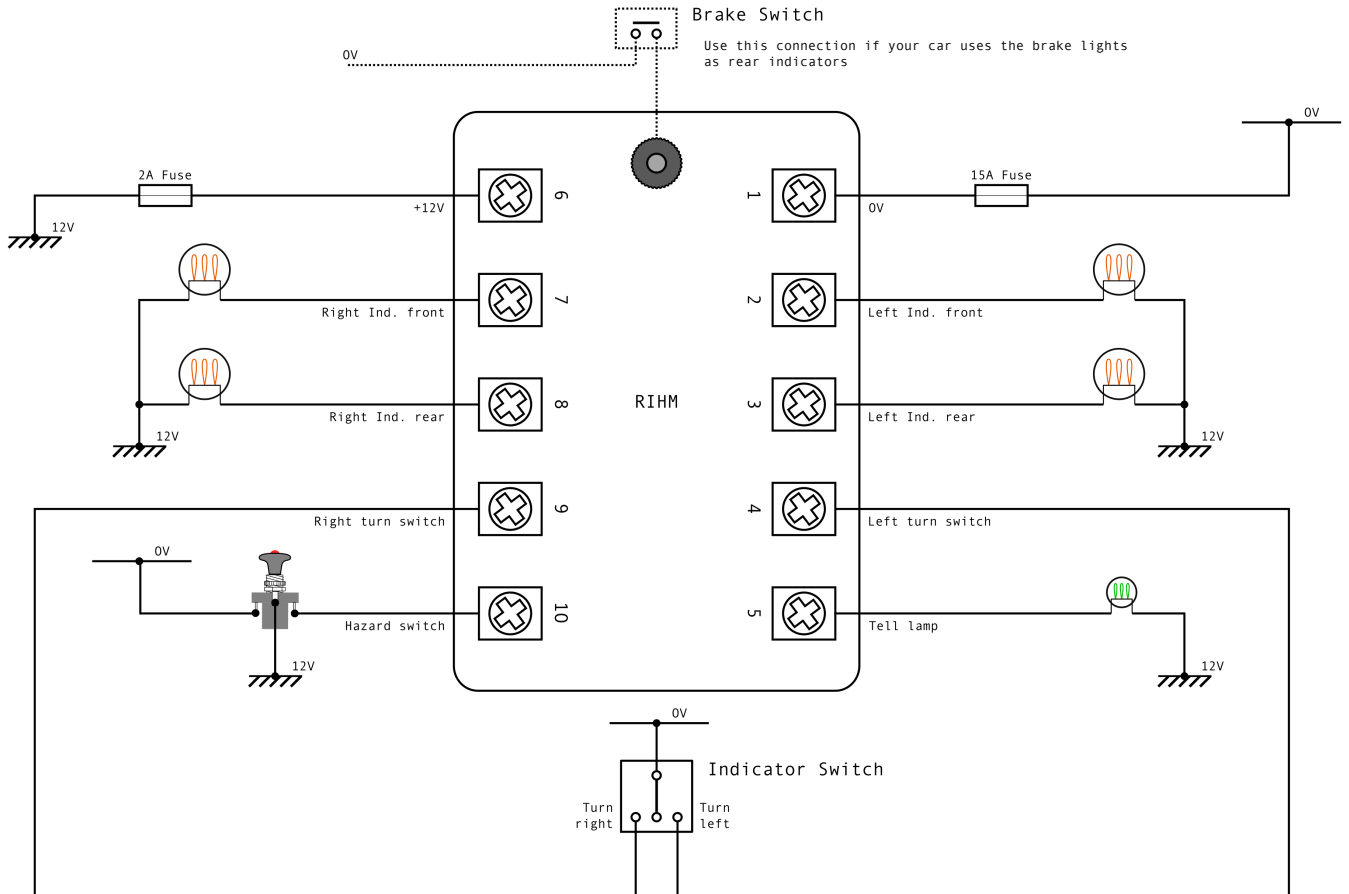

Retronics Ltd, The Generator Hub, Kings Wharf, The Quay, Exeter, Devon, EX2 4AN.
Registered in England, registration number: 12280789

This product is not recyclable. Please check with your local authority for suitable end of product life disposal.

DISCLAIMER: This product is GPSR, RoHS, CE, UKNI & UKCA compliant. The RIHM is a generic after market product designed to be compatible with the standard wiring systems of many classic vehicles, Retronics Ltd can not guarantee compatibility with all vehicles. It is for the purchaser to satisfy themselves as to the suitability of the RIHM for their vehicle. Retronics Ltd will not be liable for any loss or damage arising from unsuitable or incorrect installations.